

THE LEADING **EDGE**

VCE Units 3 & 4

Visual Communication and Design

David Morrison

Contents

Preparing for Exams	1
Cram Notes Unit 3	5
Cram Notes Unit 4	40
Handling Exam Questions	48
Getting the Edge	51
Practice Examination 1	87
Answers	101
Practice Examination 2	109
Answers	125
Tear Outs	
Daily Study Planner	133
Ready-for-it Checklist	135



This icon indicates that you can find relevant weblinks at
www.hi.com.au/theleadingedge

Cram Notes Unit 4

Designing to a brief

These Cram Notes summarise key concepts and content for Visual Communication and Design Unit 4, following the requirements of each Area of Study in the VCAA Visual Communication and Design Study Design. Use them to help you revise your knowledge and understanding of what will be tested in the external exam.

Visual Communication and Design Unit 4 is made up of three areas of study:

- Area of Study 1 The brief
- Area of Study 2 Developmental work
- Area of Study 3 Final presentations

In the Visual Communication and Design end-of-year exam you will be tested on Unit 3 – Areas of Study 1, 2 and 3 and Unit 4 – Areas of Study 1 and 2. Unit 4 Area of Study 3 will be assessed as a component of the Unit 4 school-assessed task. The following notes will assist you in revising Unit 4 for the end-of-year exam, which will test your knowledge of material from Visual Communication and Design Units 3 & 4 and will contribute 34% to your study score.

While very little of the content of Unit 4 will appear in your examination it is important that you are familiar with certain key aspects of it. Unit 4 is essentially a practical unit focused on the development of a design brief, a folio of work prepared in response to that design brief and two distinct final presentations. In an examination situation the way that Unit 4 content may appear is in the form of a specific design task.

You may be asked to redesign a logo or label, for example. In such a situation you would be given clear instructions about what you could and could not do and you would be supplied with visual material (images and letterform) to assist you in developing a response. Under examination conditions you cannot complete an entire design process (as you are unable to conduct research).

If you are confronted with such a question it is important that you recall your own approach to developing a design solution. Remember that you have knowledge of and skills in the use of design elements and design principles. Many students develop solutions without considering the use of these essential tools and their results suffer as a consequence. Remember to read the examination question carefully and pay close attention to the instructions. In a design task given under examination conditions, there will always be restrictions and limitations. For example:

- you must use colour in your response or
- the response must include cropping.

It is therefore expected that you will not only know what these terms mean but that you are also capable of applying them to a design response, under the pressure of limited time.

The key words are therefore: **design brief**, **design process** and **final presentation**.

In this section much of what has been stated for the different outcomes in Unit 3 will be revisited, but the emphasis here is on your own understanding and application of a design process. While in Unit 3 Outcome 3 you studied the design process of a professional practitioner, Unit 4 requires you to gain skills and knowledge from the development of your own response to a design brief.

Area of Study 1: The brief

Outcome 1

On completion of this Unit the student should be able to prepare one brief that describes a client's communication need and specifies possible resolutions, and proposes two distinct final visual communication presentations suitable for a stated audience(s).

Study Design checklist

The VCAA *Visual Communication and Design Study Design* states that to achieve this Outcome a student will need to draw on knowledge and related skills outlined in Area of Study 1. The tables below state the key knowledge and skills you will need to have acquired throughout the Unit of Study.

Use the tables as a checklist by placing a tick in the appropriate space to ensure that you are familiar with the key knowledge and key skills.

Key knowledge	
The communication need of a client, including constraints and expectations	
The purpose, including the audience characteristics, of each visual communication	
The context and presentation format of each visual communication; for example, a billboard located on a freeway, an interactive website, an A4 full colour magazine page, an architectural model for public display	

Key skills	
Identify the communication need of the client	
Describe the purpose of each visual communication, including audience characteristics	
Propose possible resolutions to the brief for the production of two distinct final visual communication presentations on two presentation formats	

Visual Communication and Design Study Design, Victorian Curriculum and Assessment Authority 2003, pages 28, 29.

For an understanding of this Outcome you are required to display your knowledge acquired through exploring the concept of a communication need. A communication need can be expressed in a variety of forms depending on the nature of the task, but in this instance it is expressed through a design brief.

A design brief contains the communication need but in addition to that need it describes the:

- client
- audience
- specific purpose(s)
- context
- constraints and limitations
- presentation format(s)
- evaluation methods.

It is important that you reflect on how you fulfilled this requirement when you developed your own design brief for your Unit 4 folio.

- What was the need for which you were required to develop a solution?
- How much information did you require about the client? For example, name, address, contact information, company position, etc.

- What was the purpose of your two final presentations and how did you ensure that the purpose was met?
- In what different contexts were your final presentations to be used/placed?
- What constraints and limitations did you impose upon the development of the communication need? Was there a colour, size, weight, cost or time limit?
- What style of final presentations did you develop?
- How did you evaluate the success of your final presentations?

It is important that you recognise the link between your own work and that of design practitioners so that you reinforce your understanding of this important part of the study of Visual Communication and Design – the design process.

Hint:

- Re-read your design brief and reflect on how many times you needed to refer to it and the changes that it went through.
- Review how you researched and how you evaluated (annotated) that research.
- How did you generate ideas? What materials and media were used?
- When refining your ideas did you refer to the design brief to ensure that you were developing concepts relevant to the stated need?
- Did you explore design elements and design principles to assist you in achieving the desired purpose and relevant context?
- Did you seek advice and opinions before developing your final mock-up (evaluation)?
- What formats were required for your final presentations and how did you present these solutions to your client (VCAA)?
- What process did you use to evaluate your final presentations; to look at the design brief and to ask the audience for opinions?

In reflecting in this way, you will deepen your understanding of the terminology of the design process, its cyclical nature and the stages involved in working from a brief to final presentations.

Area of Study 2: Developmental work

Outcome 2

On completion of this Unit the student should be able to prepare developmental work that explores design concepts relevant to the requirements of the brief developed for Outcome 1 and that fulfils the requirement of that brief.

Study Design checklist

The *VCAA Visual Communication and Design Study Design* states that to achieve this Outcome a student will need to draw on knowledge and related skills outlined in Area of Study 1. The tables on the next page state the key knowledge and skills you will need to have acquired throughout the Unit of Study.

Use the tables as a checklist by placing a tick in the appropriate space to ensure that you are familiar with the key knowledge and key skills.

Key knowledge	
The cyclical nature of the design process, including ongoing evaluation in response to the brief	
Information researched, analysed and interpreted to fulfil the specifications of the brief	
The range of design concepts explored, developed and refined through the application of materials, methods, including freehand drawing, media, design elements, design principles, and presentation formats (for example, two-dimensional surfaces and three-dimensional models)	
Two-dimensional and three-dimensional applications, for example, two-dimensional layout, three-dimensional form	
Selection and further development of possible solutions to satisfy the brief in terms of the client need/s, purpose/s, and intended audience/s	
The layout of the information to refine the preferred options, including concept drawings and mock-ups	

Key skills	
Apply the design process appropriate to the brief	
Research, analyse and interpret information relevant to the brief	
Generate, explore and develop design concepts using and applying design elements, design principles and presentation formats	
Experiment with the application of media, methods and materials	
Use two-dimensional and three-dimensional applications	
Select and further develop possible design solutions appropriate to the brief	
Refine the layout of the information of the preferred option	
Apply appropriate Australian Standards conventions if required by the brief	
Annotate and evaluate the design concepts explored in the developmental work	

Visual Communication and Design Study Design, Victorian Curriculum and Assessment Authority 2003, pages 29, 30.

Once again, through your own application of the design process, you are given the opportunity to enhance your understanding of the skills and knowledge necessary to fulfil the requirements of a brief.

In the preparation for your examination it is essential that you review all the stages, decisions and skills applied in your own folio work so that you are thoroughly familiar with the process of design.

In reviewing your folio developmental work it is also important that you note what you did, how you related that to the design brief and how you modified your ideas to ensure that the communication need was met.

Revision – Outcome 2

Fill in the following checklist to refresh your memory.

Task	Requirements	Response
Design brief	Client's needs	
	Purpose	
	Context	
	Audience	
	Expectations	
	Limitations	
	Possible final presentations	
Research	List of sources (for example, magazine, Internet, books)	
	Analysis: how did the research examples assist design development?	
Materials	List those used	
Methods	List those used	
Media	List those used	
Design elements	Which were the most successful?	
Design principles	Which were the most appropriate?	
2-dimensional	Where was this requirement evident?	
3-dimensional	Where did you apply this requirement?	
Select and refine	Which idea(s) did you select and why?	
Mock-ups	How did you present your final solutions?	
Final presentations	Which two formats were required?	
Evaluation	How did you evaluate throughout the design process? Who else did you consult?	

Getting the Edge

In this chapter, you'll find sample student answers to typical exam questions, with pointers to how to achieve exam success. (These sample answers are for reference only: don't forget that you need to produce your own work when you do the exam.)

Question 1

Presented below are two incomplete third-angle orthogonal drawings. You are required to complete the drawings by adding the missing lines according to Australian Standards conventions.

a

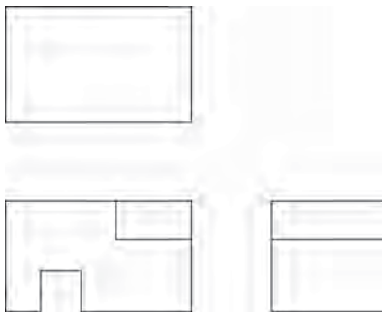

b

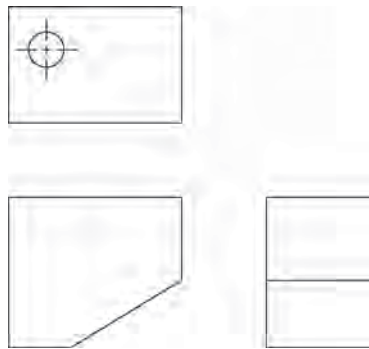

Sample lower-level answer

a

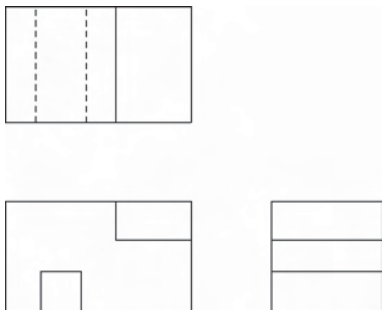

b

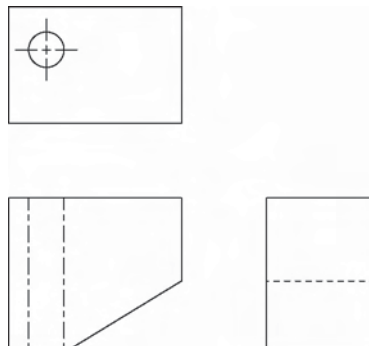

This student has correctly identified some of the required lines but in most cases has represented them incorrectly. The first drawing correctly recognises that the gap is hidden from view and hence must be represented as a broken line. The student has not, however, aligned those lines with the placement shown on the front view. The seen line on the top view is correctly identified and represented. The side view has one correct and one incorrect response. The line representing the hidden gap is shown as a solid and not as a broken line. In the second drawing the student has correctly identified and aligned the hidden circle on the top view but has selected the wrong line type to represent it. This short/long line type is used for representing the centre of a circle and not the edges of a hidden area. The line on the side view is likewise incorrect as it is represented as a hidden and not a seen line and there is no indication of the circular gap shown. In responding to this type of question it is important that you know what the three main line representations are used for and that you use a ruler to ensure that they are correctly aligned on all three views.

2/11

Sample higher-level answer

a

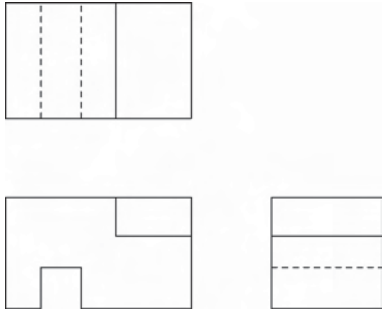

b

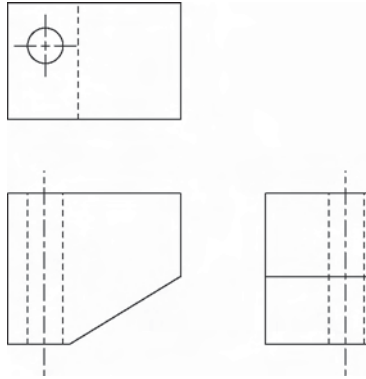

This student has clearly identified each missing line and used the correct line type, including the circle centre line, to complete the drawings. All lines are aligned as required by Australian Standards conventions. One mark has been allocated for each correct line identified.

11/11